



- // Effectively removes pipe scale, dirt and other matter from gas line
- // High flow rates
- // Can filter to 50 micron
- // Filter to 10 micron available on 60 psig (4 bar) units
- // Filter media easily replaced
- // CE certified models available

Application

Suitable for filtration of fuel gas, nitrogen and combustion air.

Specifications**Operating Limits**

Ambient temperature range:	5 °F to 176 °F (-15 °C to 80 °C)
Maximum inlet pressure:	15 psig (1 bar) and 60 psig (4 bar) version
Recommended differential pressure:	4" WC (10 mbar)

Mechanical Data

Available pipe sizes:	NPT-threaded: ½", ¾", 1", 1½", 2", 2½" ANSI-flanged: 2", 2½", 3", 4"
-----------------------	---

Material of Construction:

Housing:	GFK ½" to 4": AISi
Filter pad:	polypropylene fleece / 50 µm
Special Filter pad:	polypropylene fleece / 10 µm

Special Features

Pressure test point at the inlet and outlet available

Installation

Into horizontal and vertical pipework. The housing cover should be removable at the side so that no dirt gets into the housing during maintenance.

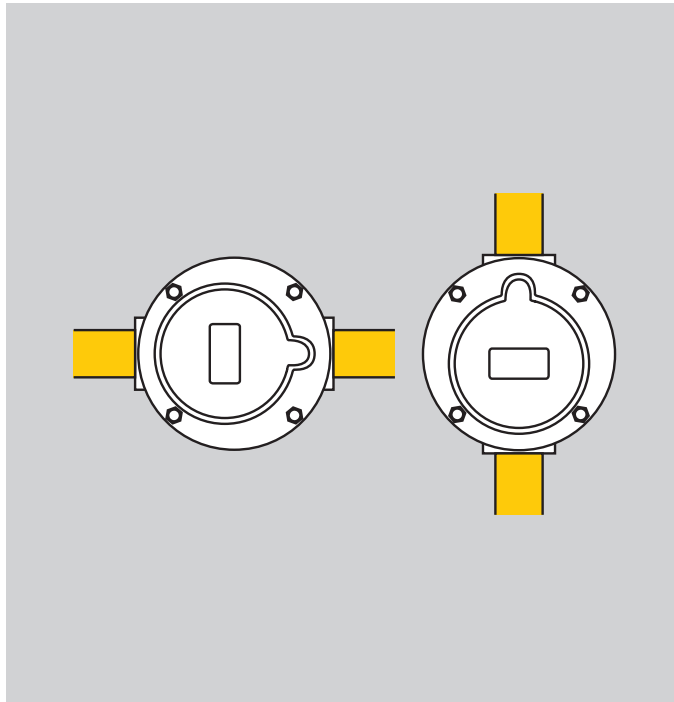

Sizing

Maximum Flow Capacity with natural gas, SCFH (m³/h) pressure drop through filter at 15 psig (1 bar) inlet pressure

Type	1" WC SCFH	2.5 mbar m ³ /h	2" WC SCFH	5 mbar m ³ /h	3" WC SCFH	7.5 mbar m ³ /h	4" WC SCFH	10 mbar m ³ /h
GFK 15	300	8.5	470	13.3	510	14.4	600	17
GFK 20	455	12.9	775	22	815	23	960	27.2
GFK 25	850	24	1,100	31.1	1,460	41.3	1,600	45.3
GFK 40	1,800	60	2,090	59.1	3,000	85	3,500	99.1
GFK 50	2,400	68	3,250	92.0	4,040	114	4,900	138.8
GFK 65	5,200	147	6,500	184.1	8,000	226.5	9,200	260.5
GFK 80	7,500	212	10,200	288.8	13,200	374	14,500	410.6
GFK 100	10,500	298	15,000	424.4	18,000	510	21,000	594.6

The above chart is accurate at sea level altitude and 60 °F (16 °C).
Mass flow will decrease at higher temperatures and altitudes.

To estimate flows for other medias across the filter, multiply figures in the table by these factors:

Medium	Air	Propane	Butane
Flow Multiplication Factor	0.774	0.640	0.547

When reading the above chart you must apply actual ft³/h (m³/h).

With another inlet pressure than 15 psig (1 bar) the real pressure drop Δp_{real} must be calculated as follows:

$$\Delta p_{\text{real}} = \Delta p_{\text{read}} * \frac{p_e + 14.5}{29} \text{ "WC}$$

This calculated pressure drop Δp_{real} must not exceed 4" WC (10 mbar).

Example:

inlet pressure: 10 psig

operating flow rate: 8000 ft³/h

filter chosen from the chart: GFK 65

pressure drop read Δp_{read}: 3" WC

$$\Delta p_{\text{real}} = 3 * \frac{10 + 14.5}{29} \text{ "WC} = 2.5 \text{ "WC}$$

The real pressure drop Δp_{real} is less than 4" WC (10 mbar), therefore, the correct filter size has been chosen.

Dimensions and Weights

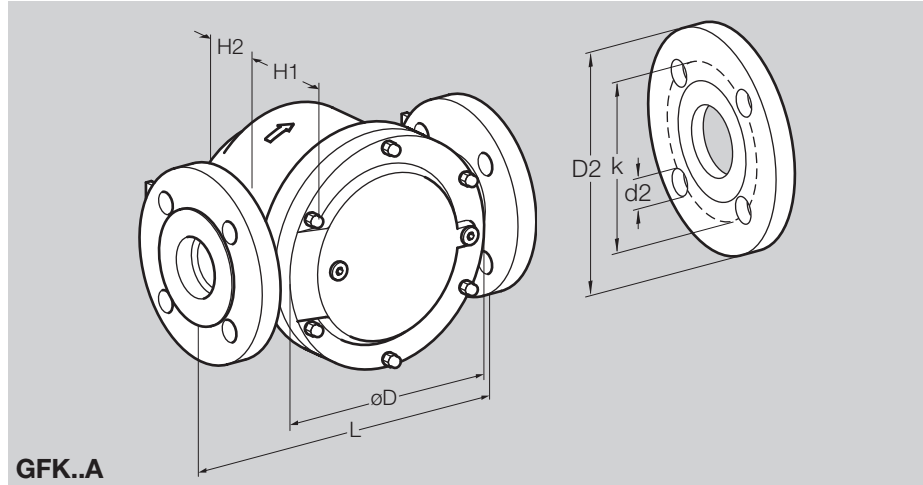
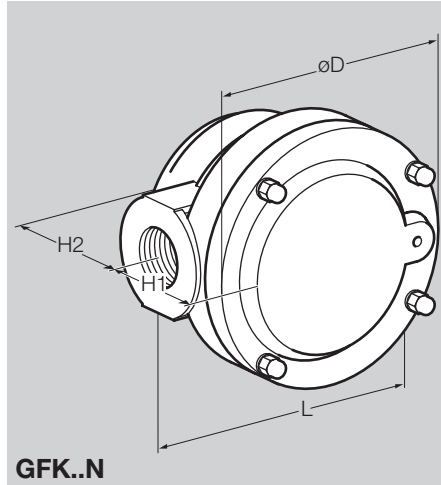

Type	Connection		Dimensions								Flange ANSI 150				Bore		Weight		Filterpad		
	NPT	DN	L	øD	H1	H2	D2	k	d2	No.	lbs	kg	inch ²	cm ²							
	ANSI	IN	mm	IN	mm	IN	mm	IN	mm	IN	mm	IN	mm	IN	mm						
GFK 15TN	½	15	3.62	92	3.46	88	2.36	60	1.30	33	-	-	-	-	-	-	0.8	0.4	9.3	60	
GFK 20TN	¾	20	3.62	92	3.46	88	2.36	60	1.30	33	-	-	-	-	-	-	0.8	0.4	9.3	60	
GFK 25TN	1	25	5.35	135	5.28	134	2.36	60	1.73	44	-	-	-	-	-	-	1.7	0.8	21	135	
GFK 40TN	1½	40	8.19	208	5.28	182	3.15	80	0.24	64	-	-	-	-	-	-	4.4	2.0	52	335	
GFK 50TN	2	50	8.19	208	5.28	182	3.15	80	0.24	64	-	-	-	-	-	-	4.9	2.2	52	335	
GFK 65TN	2½	65	8.66	220	5.28	182	4.33	110	3.78	96	-	-	-	-	-	-					
GFK 50TA	2	50	9.84	250	5.28	182	2.95	75	2.48	63	5.98	152	4.76	121	0.75	19	4	9.3	4.2	52	335
GFK 65TA	2½	65	9.84	250	5.28	182	3.86	98	3.78	96	7.01	178	5.51	140	0.75	19	4	11.5	5.2	84	545
GFK 80TA	3	80	13.0	330	10.3	262	4.65	118	3.43	87	7.52	191	5.98	152	0.75	19	4	17.6	8.0	122	790
GFK 100TA	4	100	13.8	350	10.3	262	4.92	125	4.72	120	9.02	229	7.52	191	0.75	19	8	20.5	9.3	145	940

Order Information

Filters GFK

GFK	gas filter
½" to 4" (DN 15 to 100)	nominal diameter
T	T-product
N	NPT-internal thread
A	ANSI flange
10	max inlet pressure 15 psig (1 bar)
40	max inlet pressure 60 psig (4 bar)
-0	without pressure test point
-3	screw plug at the inlet and outlet

Warning:

Situations dangerous to personnel and property can result from the misapplication and incorrect operation of combustion equipment. Kromschroder advises compliance with the National Fire Protection Association standards that apply for related equipment and Insurance Underwriters recommendation, and care of operation.

We reserve the right to make technical changes designed to improve our products without prior notice. For current product information, visit our website at www.kromschroder.com.



Elster Kromschroder GmbH
 Postfach 2809, D-49018 Osnabrück
 Ph. ++49 (0) 541/1214-0, Fax ++49 (0) 541/1214-370
 info@kromschroder.com, www.kromschroder.com

KROMSCHRODER INC.
 1595-H Georgetown Rd., Hudson, OH 44236,
 Ph. 330-342-0595, Fax 330-342-0596,
 info@kromschroder.com, www.kromschroder.com